

Cleaning and Care of Printheads

(Applicable machines – 64-0X, ALX92X, ALX73X, XTP804)

Paper dust and coloured particles from the thermal transfer ribbon may collect on the printhead during printing. Over time, this can significantly impair the printing quality in the following ways:

- Contrast differences in label
- Bright strips in printing direction

The print head should be cleaned on replacement of every roll of ribbon, or after every label roll if printing on direct thermal labels.

- **Switch off** the machine.
- Remove label material and ribbon.
- Remove any electrostatic charges from body by touching the base plate of the printer.
- Mark the outer position of the printhead on the axle and unscrew the two thumbscrews (A) to allow the printhead to swivel upwards.

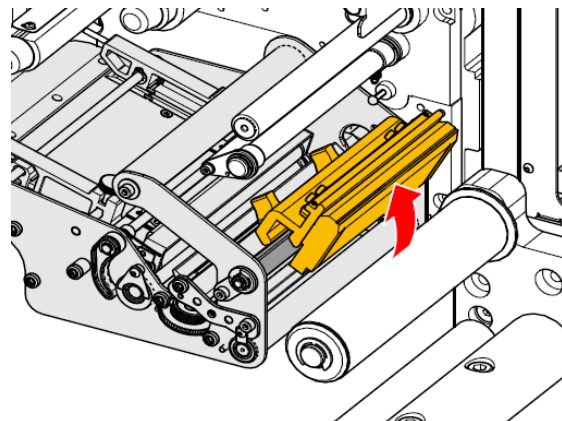
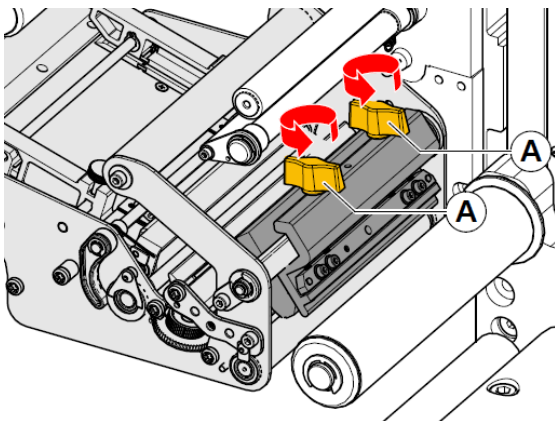

- Clean the printhead with a lint free cloth and label remover or an alcohol wipe, wiping across the edge of the print head. **DO NOT use any sharp or metal objects as this may damage the printhead beyond repair.**

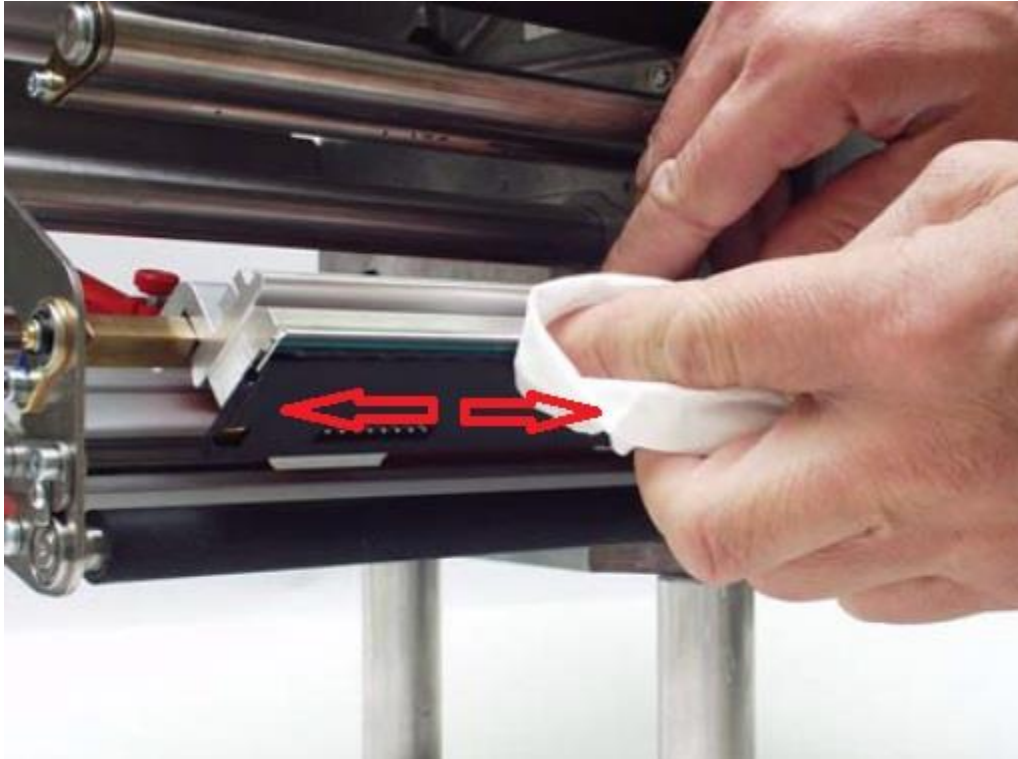

- Return the printhead to its marked position and tighten the thumbscrews.
- Before powering back on, check that the printhead cable plugs have not come loose as plugging these in or out with the printer powered on can result in damage to the print head or the printer power supply unit.